

*hy-gain* VII

by ***hy-gain***

**MODEL 3087
CITIZENS TWO-WAY RADIO
Base Station**

**Manufactured and Distributed by
Hy-Gain de Puerto Rico, Inc.
P.O. Box 68 State Hwy. 31, Km. 4.0
Naguabo, Puerto Rico 00718**

EO-3087-A-105



First Printing February, 1977
Original Edition, February, 1977

TABLE OF CONTENTS

	page
CHAPTER 1 - GENERAL INFORMATION	1
Introduction	1
Warranty Service Department	1
How to Ship Returns	1
Purchase of Parts	2
Specifications	2
CHAPTER 2 - THEORY OF OPERATION	3
General	3
Phase Locked Loop Frequency Synthesizer	3
Receiver	5
Transmitter	6
Power Supply	6
CHAPTER 3 - ALIGNMENT	9
General	9
Recommended Equipment	9
Setting the Power Supply Output Voltage	9
Wiring Model 3087 for 240 VAC	11
Transmitter Alignment Procedure	11
Equipment Set-up	11
Pre-Alignment Frequency Check	11
VCO Alignment	12
RF Output Adjustment	12
Transmitter Frequency Check	12
Modulation Sensitivity Alignment	13
Receiver Alignment Procedures	14
Equipment Set-up	14
Receiver Alignment	14
Tight Squelch Alignment	14
CHAPTER 4 - CHARTS AND DRAWINGS	19
Voltage Measurement Charts	21
Component Outline, Main P.C. Board	23
Component Outline, Power Supply P.C. Board	27
Parts List	31
Schematic Diagram	41

LIST OF ILLUSTRATIONS

Figure		page
2-1	Block Diagram of PLL Circuitry, Model 3087	4
2-2	Block Diagram, Model 3087	foldout
3-1	Before Wiring for 240 VAC	10
3-2	After Wiring for 240 VAC	10
3-3	Equipment Set-up, Transmitter Alignment	11
3-4	Connection of Frequency Counter and Dummy Load	13
3-5	Equipment Set-up, Receiver Alignment	14
3-6	Components Adjusted for Power Supply Alignment	15
3-7	Components Adjusted for Transmitter Alignment	16
3-8	Components Adjusted for Receiver Alignment	17
4-1	Component Outline Main P.C. Board, Model 3087	25
4-2	Component Outline Power Supply P.C. Board, Model 3087	29
4-3	Schematic Diagram, Model 3087	foldout

CHAPTER 1 - GENERAL INFORMATION

Introduction

This service manual contains all the information needed to service and repair the Hy-Gain VII (Model 3087) transceiver. It includes an explanation of the theory of operation and alignment procedures. Revision, addendum, and errata sheets will be published as needed. Insert them as required in the manual.

The Hy-Gain VII is a full 23-channel transceiver designed and type accepted for Class D Citizens Radio Service, as designated by the Federal Communications Commission (FCC).

It is a completely solid-state base station, highly reliable with low power consumption. The Phase Locked Loop Frequency Synthesizer provides immediate operation on all 23 channels. Use the unit with standard household power (either 120 VAC, or 240 VAC with minor wiring changes).

Warranty Service Department

For help with technical problems, for parts information, and information on local and factory repair facilities, contact the National Service Manager. When you write, please include all pertinent information that may be helpful in solving the problem. Address the letter to:

Hy-Gain Warranty Service Department
4900 Superior Street
Lincoln, Nebraska 68504
ATTN: National Service Manager

The Warranty Service Department can repair any unit. Before shipping the unit contact the National Service Manager. Often a problem is field solvable with a little extra help. This can save lost time and shipping costs. Limit factory returns to the difficult problems

How to Ship Returns

To return a unit, get a return authorization. This is important. Handling of the unit may be delayed if shipped without it. If the unit must be shipped immediately, telephone or telex the National Service Manager for expeditious service.

When you request authorization, notification of repairs may also be requested. The notification will include a copy of the bill. Paying the bill before the return of the unit can save the cost of a COD fee.

For warranty repair, prepare a letter in duplicate containing the following information (for out-of-warranty repair, delete items 2 and 3):

1. your name and address
2. purchaser's name and address
3. proof of purchase
4. serial number
5. complete description of the problem
6. the return authorization

Check the unit to see that all parts and screws are in place, and attach an envelope containing a copy of the letter directly to it so this information is not overlooked. Wrap the unit and the envelope in heavy paper or put it in a plastic bag. If the original carton is not available, place the unit in a strong carton at least six inches larger in all three dimensions than the unit. Fill the carton equally around the unit with resilient packing material (shredded paper, excelsior, bubble pack, etc.). Seal the box with gummed paper tape, tie it with a strong cord, and ship it by prepaid express, United Parcel Service, or insured parcel post to the address given previously. Mail the original of the letter in a second envelope to that same address.

It is important that the shipment be well-packed and fully-insured. Damage claims can delay repair and return of the unit. All claims must be settled between you and the carrier.

All shipments must be sent PREPAID. We *do not* accept collect shipments. After the unit has been repaired, we will send it back COD unless the bill has been prepaid. Unclaimed or refused COD shipments will not be reshipped until payment in full is received. These items become the property of Hy-Gain 60 days after refusal or return and will be sold for payment of charges due.

Units with unauthorized field modifications cannot be accepted for repair.

Purchase of Parts

Parts can be purchased from any Hy-Gain Service Center or from the factory Warranty Service Department. When ordering, please supply the following information:

1. unit model number
2. unit serial number
3. part description
4. part number

Specifications

General

Channels all 23 channels in the Citizens Band
(26.965 MHz - 27.255 MHz)

Antenna impedance 50 ohms, nominal

Power requirement..... 11.5 VDC - 14.5 VDC negative or positive
ground. 120 VAC, 50/60 Hz; or 240 VAC with
modification

Compliance type accepted under FCC Rules, Part 95

Receiver Section

Circuitry dual conversion superheterodyne with rf
amplifier stage and 455 kHz ceramic filter

Sensitivity..... 0.7 uV for 10 dB (S+N)/N ratio

Intermediate frequency 1st IF - 10.695 MHz
2nd IF - 455 kHz

Audio output 3 watts, maximum

Current drain, receive about 300 mA (no signal)

Transmitter Section

RF power output 4 watts

Emission AM, type 6A3

Spurious response rejection all harmonic and spurious suppression better
than FCC requirements

Modulation AM, 90% typical

Current drain, transmit less than 1.2 amp @ 13.8 VDC

CHAPTER 2 - THEORY OF OPERATION

General

The theory of operation for the Hy-Gain 3087 transceiver is divided into three sections: the Phase Locked Loop Frequency Synthesizer, the Receiver, and the Transmitter. This material covers the functioning of the transceiver with a minimum of technical involvement. We have not attempted to explain the engineering techniques and approaches that arrived at these circuit designs.

Refer to the block diagram Figure 2-2 for visual reference to the theory of operation.

Phase Locked Loop Frequency Synthesizer

The Phase Locked Loop (PLL) Frequency Synthesizer generates frequencies for use in both the transmitter and receiver sections. Its output determines the channel on which the transceiver is operating. The PLL circuitry incorporates three crystal oscillators to perform its frequency generating function.

The 11.8066 MHz Oscillator, Q105, has its output tripled and serves as a prescaler for the output of the Voltage Controlled Oscillator (VCO), Q101. The Offset Oscillator, Q109, operates at a frequency of 10.695 MHz, which mixes with the VCO output to provide the transmit frequency. The 10.24 MHz Oscillator, Q117, provides a reference for the PLL and an injection frequency for the Second Receiver Mixer.

The PLL circuit generates the operating frequencies needed for the transceiver in accordance with the code fed to the programmable divider of IC101, from the channel selector switch. Table A shows the following for each channel: the channel frequency, VCO frequency, binary code and the division ratio of the programmable divider.

For example, assume that channel 1 has been selected. The channel frequency is 26.965 MHz, the VCO frequency is 37.660 MHz, and the binary code ("N" code) is 224. The channel selector switch programs the Programmable Divider for a division ratio of 224. The 10.24 MHz reference frequency is fed to the Integrated Circuit PLL Chip, IC101. It is divided by 1024 within the chip, producing a 10 kHz reference signal. The output of the VCO is mixed in the PLL Mixer, Q102, with the tripled output of Q105, producing a 2.24 MHz signal. This signal is fed to the Programmable Divider, which divides it by 224 to produce 10 kHz.

The two 10 kHz signals are phase compared in the phase detector within IC101 producing a DC voltage. This DC voltage controls the varactor diode, D10, and holds the VCO frequency at 37.660 MHz.

Assume that the channel is changed to channel 23. The channel selector switch now provides a code that will produce a division ratio of 253. At this instant the VCO frequency is at 37.660 MHz, which is mixed with the tripled output of Q105. Again, the PLL Mixer, Q102, produces an output of 2.24 MHz. The 2.24 MHz signal is divided by 253 to produce a frequency of 8.73 kHz.

The 8.73 kHz output, along with the 10 kHz obtained from the reference oscillator, is fed to the phase detector. The comparison of the two frequencies in the phase detector produces an error output which is a combined AC-DC voltage. The low pass filter removes the AC component and allows only the DC voltage to be fed to the VCO. The VCO frequency changes until the output of the programmable divider is again 10 kHz. When the two frequencies are matched at 10 kHz, the error voltage output of the phase detector is zero.

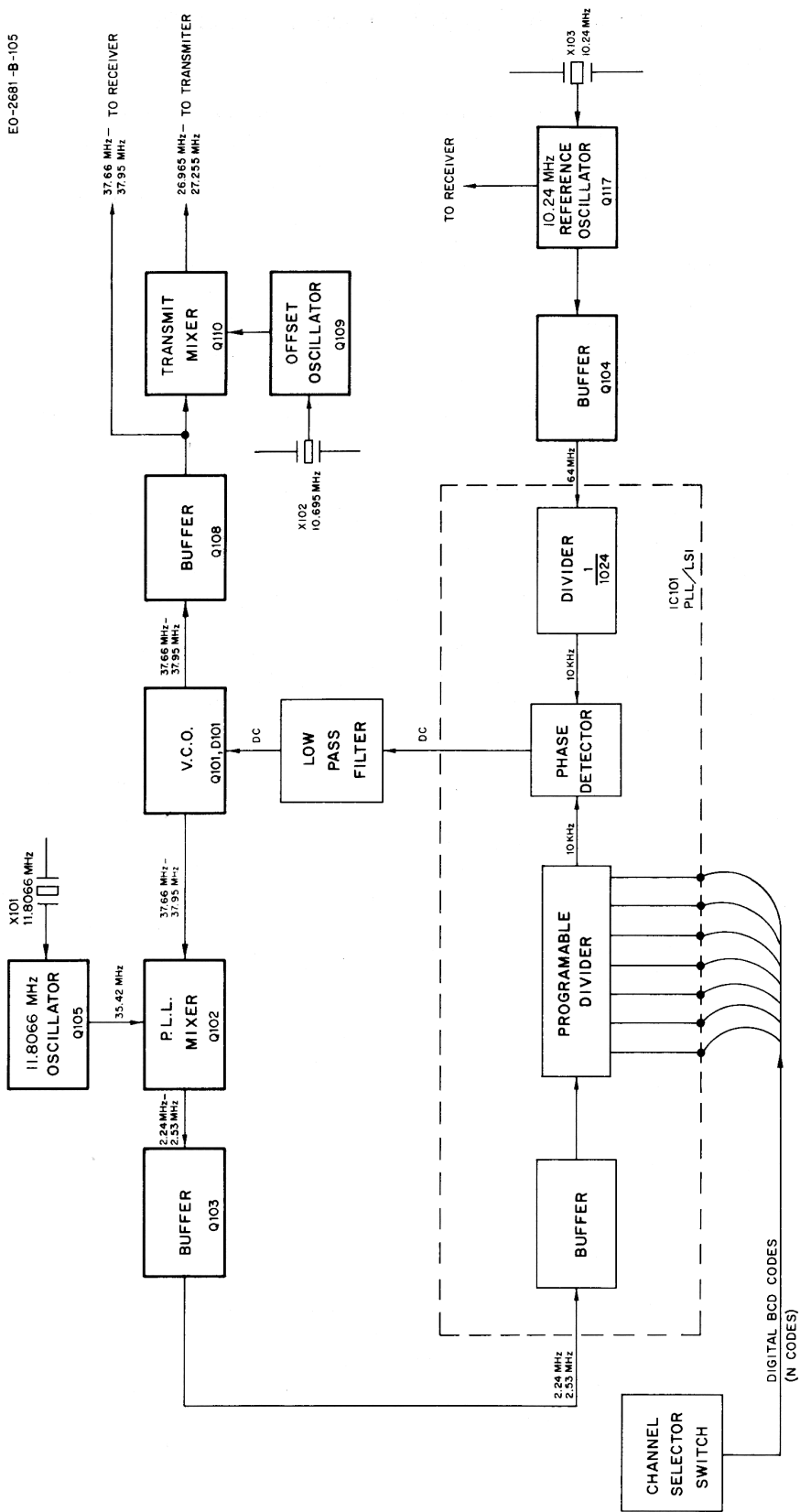

Figure 2-1. Block Diagram of PLL Circuitry, Model 3087

There is now a new DC voltage set up to tune the VCO frequency to 37.950 MHz. When this occurs the Loop is considered locked. With the channel selector at 23, the following outputs of the PLL circuitry are produced: the 37.950 MHz VCO output is fed to the First Receiver Mixer and, in the transmit mode, is mixed with the 10.695 MHz output of Q109 to produce a transmit frequency of 27.255 MHz.

Receiver

The receiver is a dual-conversion superheterodyne, receiving AM signals from 26.965 MHz to 27.255 MHz. The operating channel is determined by the PLL Frequency Synthesizer, which provides the local oscillator frequency to the First Mixer. A variable squelch circuit is included to quiet the receiver between transmissions.

In the receive mode, 13.8 VDC is supplied to IC102, Q14, Q115, Q118, Q119 and to Q106 (the AVR). The AVR supplies regulated voltage to the synthesizer stages and to the Reference Oscillator, Q117. A bias voltage is also applied to the base of the Transmit Switch keeping it open, so that the transceiver circuits remain in receive.

Radio signals are received by the antenna and enter the radio at the antenna jack. The filter formed by L109, L110, C152, and C1 matches the antenna impedance to the RF Amplifier. Signals in the 26.965 MHz - 27.255 MHz range are filtered out and amplified by the RF Amplifier, Q114, and its tuned circuit C154/T104 and T105. D107 is a signal overload protector.

The output of the RF Amplifier and the buffer VCO signal (which in this case could be called the "first local oscillator frequency") are applied to the First Receiver Mixer and produce an output of 10.695 MHz, which is the first IF.

The first IF passes through tuned circuits L112 and T106. It is then applied to the Second Receiver Mixer, Q116, along with 10.240 MHz from the Reference Oscillator, Q117. The two signals are mixed the Second Receiver Mixer and produce an output of 455 kHz, which is the second IF.

The second IF passes through the Ceramic Filter, CF101, and is amplified by Q118 and Q119. The amplified signal is then fed to the Detector, D110. The Detector establishes an automatic gain control (AGC) voltage and recovers the audio from the modulated signal. The AGC voltage maintains the output volume of the receiver constant under variations in input signal strength and also controls the Squelch Switch, Q120.

The squelch functions in the following manner: in the receive mode, a bias voltage from Q106 is applied to the base of Q120, as determined by RV101. In the absence of a signal, the base of Q120 is positively biased and is on. This biases the squelch transistor inside IC102, which turns off the Audio Amplifier and squelches the receiver. When a signal is received, the AGC voltage developed by D110 biases Q120 off. This biases the squelch transistor inside IC102 such that the audio amplifier is turned on and the signal is heard.

The recovered audio from the Detector passes through a series Automatic Noise Limiter (ANL), D108. The output of the ANL goes through the volume control, VR1, and is RC coupled to the Audio Amplifier, IC102. The amplified audio output from IC102 passes through the audio transformer, T110, to be applied to the speaker jacks and the speaker.

Transmitter

Switching to the transmit mode is accomplished in the following manner: when the PTT switch is closed, the base of the DC Switch, Q107, is grounded. This establishes forward bias which causes Q107 to conduct. Regulated voltage from the Voltage Regulator (AVR), Q106, is then supplied through Q107 to Q109 and Q110. RF is now applied to Q111, Q112 and Q113.

The operating channel is determined by the PLL Frequency Synthesizer. The buffered VCO frequency is mixed in Q110 with the 10.695 MHz Offset Oscillator, Q109, output to yield the transmit frequency. The frequency from Q110 passes through the filter circuit of L103, L104, and T102 and is applied to the Pre-driver, Q111. The filter circuit partially removes spurious signals from the transmit frequency.

The Pre-driver, Q111, and the Driver, Q112, form two stages of amplification leading to the final stage. The filter circuit of T103 follows Q111, and L106 follows Q112. These two circuits filter out the remaining spurious signals from the transmit frequency.

From the Driver the signal is applied to the final stage, the RF Power Amplifier, Q113. This is a current amplifier that raises the transmit signal to an output of four watts. Its output is applied to a filter, consisting of L109, C152, L110 and C1, and then to the antenna jack.

The transmit signal is modulated in the following manner: microphone output is applied to the Audio Amplifier, IC102. The output is applied to the collectors of Q112 and Q113 through the audio output transformer, T110. Control voltages for the transmit audio (ALC), Q122, and the Range Boost, Q121, come from detector diode D111. The transmit audio ALC boosts or lowers the amplifier gain in response to line voltage fluctuations. This ensures full modulation of the carrier, despite any changes in line voltage. The Range Boost reduces AF peaks so that a higher average AF level is supplied to the Audio Amplifier. This gives the desired high average modulation without overmodulation peaks.

Power Supply

This is a series-regulated power supply circuit employing a Darlington-connected pair of transistors as the pass element. The bridge rectifier of D1 - D4 supplies 22.1 VDC to the high-gain pass element of Q1 and Q3. Zener diode ZD2 provides a voltage reference for Q2. Q2 is in turn a current regulator for the pass element. Q2's base is biased by the output of Q3. This feedback loop enables the output voltage of Q3 to be held at a constant 13.8 VDC, when RV1 is set correctly.

N CODE — FREQUENCY CORRELATION CHART

Channel No.	Channel Frequency	"N" Code	V.C.O. Frequency	Channel Switch Output (PLL Inputs)				
				A	B	C	D	A
1	26.965 MHz	224	37.660 MHz	0	0	0	0	0
2	26.975 MHz	225	37.670 MHz	1	0	0	0	0
3	26.985 MHz	226	37.680 MHz	0	1	0	0	0
4	27.005 MHz	228	37.700 MHz	0	0	1	0	0
5	27.015 MHz	229	37.710 MHz	1	0	1	0	0
6	27.025 MHz	230	37.720 MHz	0	1	1	0	0
7	27.035 MHz	231	37.730 MHz	1	1	1	0	0
8	27.055 MHz	233	37.750 MHz	1	0	0	1	0
9	27.065 MHz	234	37.760 MHz	0	1	0	1	0
10	27.075 MHz	235	37.770 MHz	1	1	0	1	0
11	27.085 MHz	236	37.780 MHz	0	0	1	1	0
12	27.105 MHz	238	37.800 MHz	0	1	1	1	0
13	27.115 MHz	239	37.810 MHz	1	1	1	1	0
14	27.125 MHz	240	37.820 MHz	0	0	0	0	1
15	27.135 MHz	241	37.830 MHz	1	0	0	0	1
16	27.155 MHz	243	37.850 MHz	1	1	0	0	1
17	27.165 MHz	244	37.860 MHz	0	0	1	0	1
18	27.175 MHz	245	37.870 MHz	1	0	1	0	1
19	27.185 MHz	246	37.880 MHz	0	1	1	0	1
20	27.205 MHz	248	37.900 MHz	0	0	0	1	1
21	27.215 MHz	249	37.910 MHz	1	0	0	1	1
22	27.225 MHz	250	37.920 MHz	0	1	0	1	1
23	27.255 MHz	253	37.950 MHz	1	0	1	1	1

Table A

CHAPTER 3 - ALIGNMENT

General

These procedures must be followed to align the Hy-Gain VII 3087 transceiver. Alignment should not be undertaken unless the technician has adequate test equipment and a full understanding of the circuitry of the transceiver.

IMPORTANT: Tuning adjustment of this transceiver "shall be made by or under the immediate supervision and responsibility of a person holding a first or second-class commercial radio operator license," as stipulated in Part 95.97 (B) of the FCC Rules and Regulations.

All procedures are divided into two main sections: Transmitter Alignment and Receiver Alignment. See "Equipment" for a complete list of recommended equipment.

These procedures assume that proper voltages are present at all points in the unit, if not, troubleshoot before continuing.

NOTE: The ferrite cores in the tuned coils are easily chipped or broken. Always use care when inserting an alignment tool in the coil; insert it straight into the core.

Recommended Equipment

The following equipment is recommended for use in aligning the Hy-Gain 3087 transceiver:

- Audio Signal Generator, 1 kHz
- AC VTVM, 1 mV measurable
- DC Ampere Meter, 2A
- Variable Regulated Power Supply, 8-15 VDC, 2A or higher
- Frequency Counter, 0 - 40 MHz, high input impedance type
- VTVM with RF probe
- Oscilloscope, 30 MHz, high input impedance
- RF wattmeter and 50 ohm, 5W dummy load
- Standard RF signal generator, 27 MHz CB band
- Speaker dummy resistor, 8 ohm, 5W
- VOM 20K ohm/V

All test voltage is 13.8 VDC unless otherwise specified.

Setting the Power Supply Output Voltage

NOTE: Refer to Figure 3-6 for components adjusted for Power Supply adjustment.

1. Turn the transceiver off.
2. Adjust the output of the outside power supply for 120 VAC. Plug the transceiver power cord into the power supply.
3. Turn the transceiver on.
4. Connect the probes of the VOM to pins 3 and G of the internal supply board. Adjust RV1 of the board for the reading of 13.8 VDC.
5. Turn the transceiver off and disconnect the test equipment.

BEFORE

EO-3077-A-107

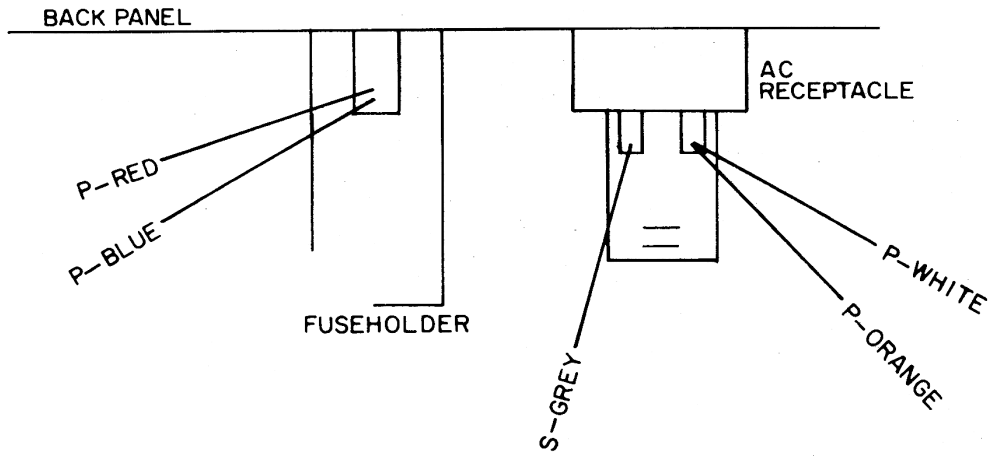

Figure 3-1. Before Wiring for 240 VAC

AFTER

EO-3077-A-110

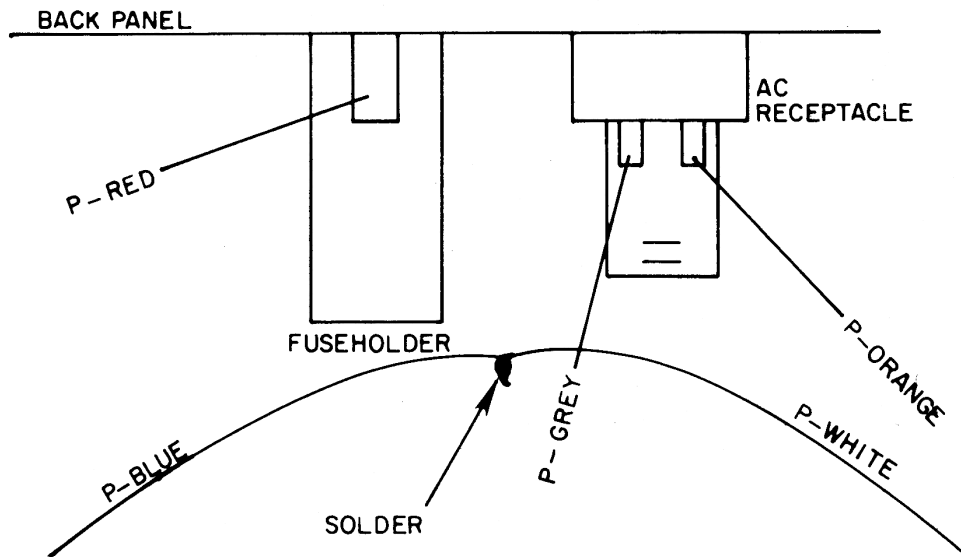

Figure 3-2. After Wiring for 240 VAC

**Wiring Model
3087 for 240 VAC**

WARNING: This unit contains voltages sufficient to kill. Disconnect the unit from the power source before attempting any wiring changes.

NOTE: See Figures 3-1 and 3-2 for wiring changes.

1. Remove the top and bottom covers by removing the five screws found in each cover.
2. Desolder the blue lead from the fuse holder and the white lead from the AC receptacle.
3. Solder the two leads together.
4. Insulate the connection and reassemble the unit.

**Transmitter
Alignment
Procedure**

Equipment Set-up

Refer to Figure 3-7 for the location of components to be adjusted for transmitter alignment.

Connect test equipment as shown below.

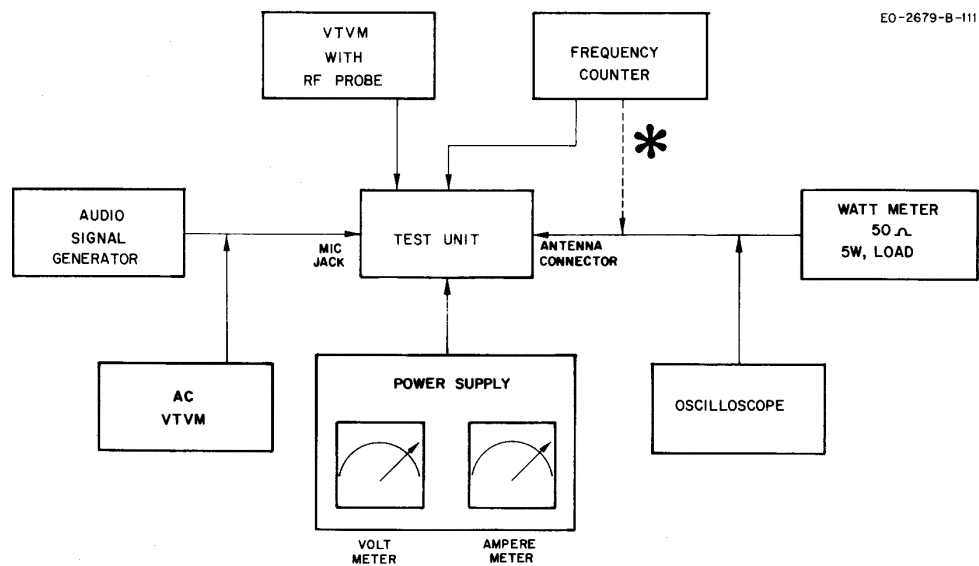

Figure 3-3. Equipment Set-up for Transmitter Alignment

***NOTE:** See Figure 3-4 for connection of the frequency counter and the dummy load.

Pre-Alignment Frequency Check

Before aligning, use the frequency counter through a 1000 pF coupling capacitor connected in series with the counter input probe to check the operating frequencies at the following points:

1. Pin 3 of IC101, reference input, check to read 10.24 MHz.

2. Q108 base, transceiver on channel 1, check to read 37.66 MHz.

VCO Alignment

1. Connect VOM (10 VDC range) across C135 and check to read 5.0V - 5.5V.
2. Place the channel selector in the channel 1 position.
3. Connect the VOM between ground and R114 (TP-8 side).
4. Adjust T101 to obtain $1.5V \pm .1V$.
5. Place the channel selector in the open channel position. A voltage reading of 5.1 to 5.4V is obtained.
6. Place the channel selector in the channel 23 position and read the value of the meter. It should be $2.7 \pm 0.6V$.

RF Output Adjustment

1. Adjust the power supply voltage to 8.0 volts.
2. Connect the VTVM RF probe between the base of Q111 and ground.
3. Set the transceiver channel selector to channel 13. Perform the following procedure on channel 13.
4. Key the transmitter.
5. Adjust the slugs of L103, L104 and T102 for a maximum reading on the VTVM.
6. Connect the VTVM RF probe between the base of Q112 and ground.
7. Adjust the slug of T103 for a maximum reading on the VTVM.
8. Adjust L109, L110 for maximum RF power output as indicated on the wattmeter.
9. Raise the power supply voltage to 13.8V.
10. Repeat steps 2 thru 8.
11. Repeat step 8 until no further improvement is noted.
12. Back off L110 (counterclockwise) for a reading of 4.0 watts RF power output.
13. Readjust L109 for maximum power out.
14. Repeat steps 12 and 13 until the maximum power output is 4.0 watts with L109 peaked for maximum output. (Total transceiver current at this setting should not exceed 1.35A.)

Transmitter Frequency Check

1. Turn the transceiver off.
2. Connect the dummy load to the frequency counter of the antenna jack as shown in Figure 3-4.

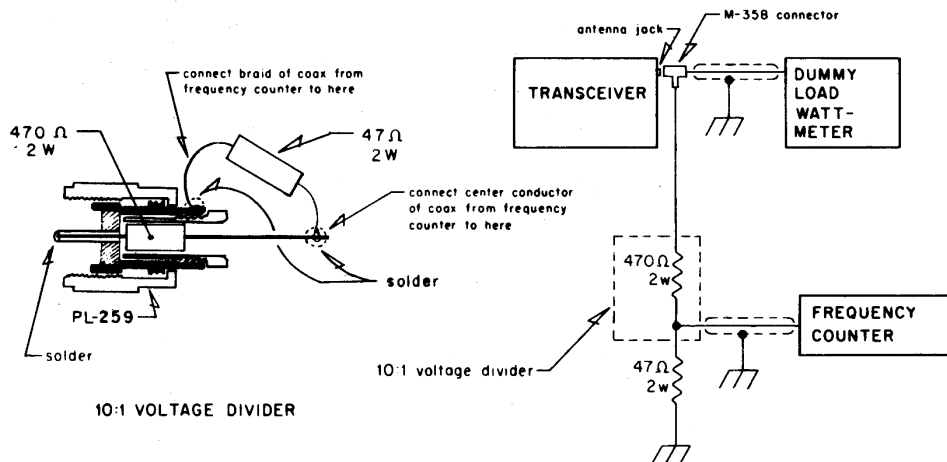

Figure 3-4. Connection of the Frequency Counter and Dummy Load

3. Key the transmitter with the microphone PTT button.
4. Check the frequency of each channel with the following chart. Frequencies should be within 800 Hz at 25 C (room temperature).

CHANNEL FREQUENCY

Channel	MHz	Channel	MHz
1	26.965	13	27.115
2	26.975	14	27.125
3	26.985	15	27.135
4	27.005	16	27.155
5	27.015	17	27.165
6	27.025	18	27.175
7	27.035	19	27.185
8	27.055	20	27.205
9	27.065	21	27.215
10	27.075	22	27.225
11	27.085	23	27.255
12	27.105		

Modulation Sensitivity Alignment

1. Place the unit in the transmit mode and apply a 20 mV, 1 kHz signal to wire wrap pin 22 on the radio PC board.
2. Adjust RV-102 to obtain 90% modulation as observed on the oscilloscope.
3. Decrease the signal input to 6 mV. Modulation should not fall below 80%.

Receiver Alignment Procedures

Equipment Set-up

Refer to Figure 3-8 for the location of components to be adjusted for receiver alignment.

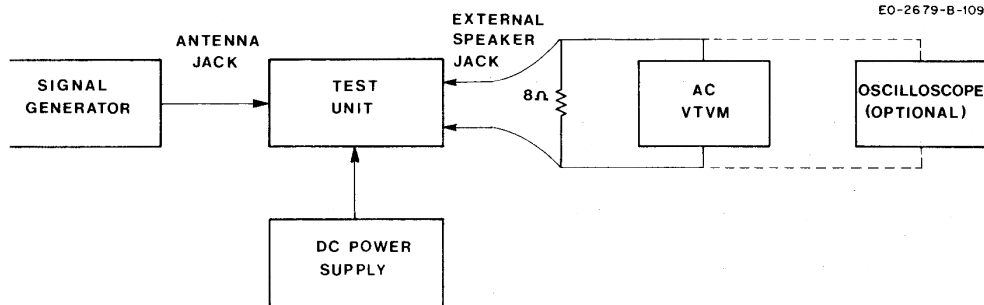

Figure 3-5. Equipment Set-up for Receiver Alignment

Receiver Alignment

1. Set the Signal Generator to 27.115 MHz \pm 1 kHz, 30% modulation and set the transceiver to channel 13.

NOTE: This alignment should be performed with a very low level signal input from the signal generator to avoid inaccurate alignment due to AGC action.

2. Adjust T104, T105, L112, T106, T107, T108 and T109 for maximum audio output as indicated on the VTVM (or oscilloscope is used).

Tight Squelch Adjustment

1. Set the signal generator to provide an RF input signal of 50uV, (1 kHz, 30% modulation).
2. Rotate the squelch control fully clockwise.
3. Adjust RV101 so that the squelch just breaks with the 50uV signal input.

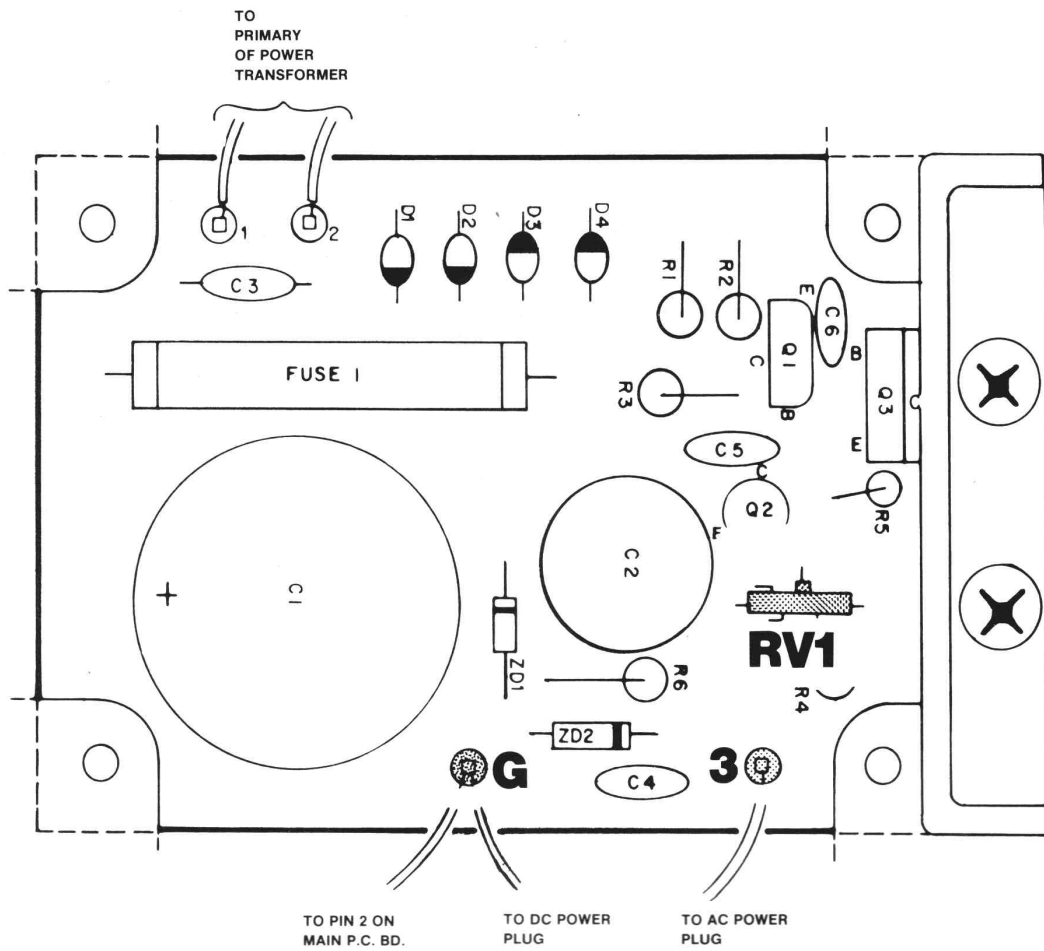
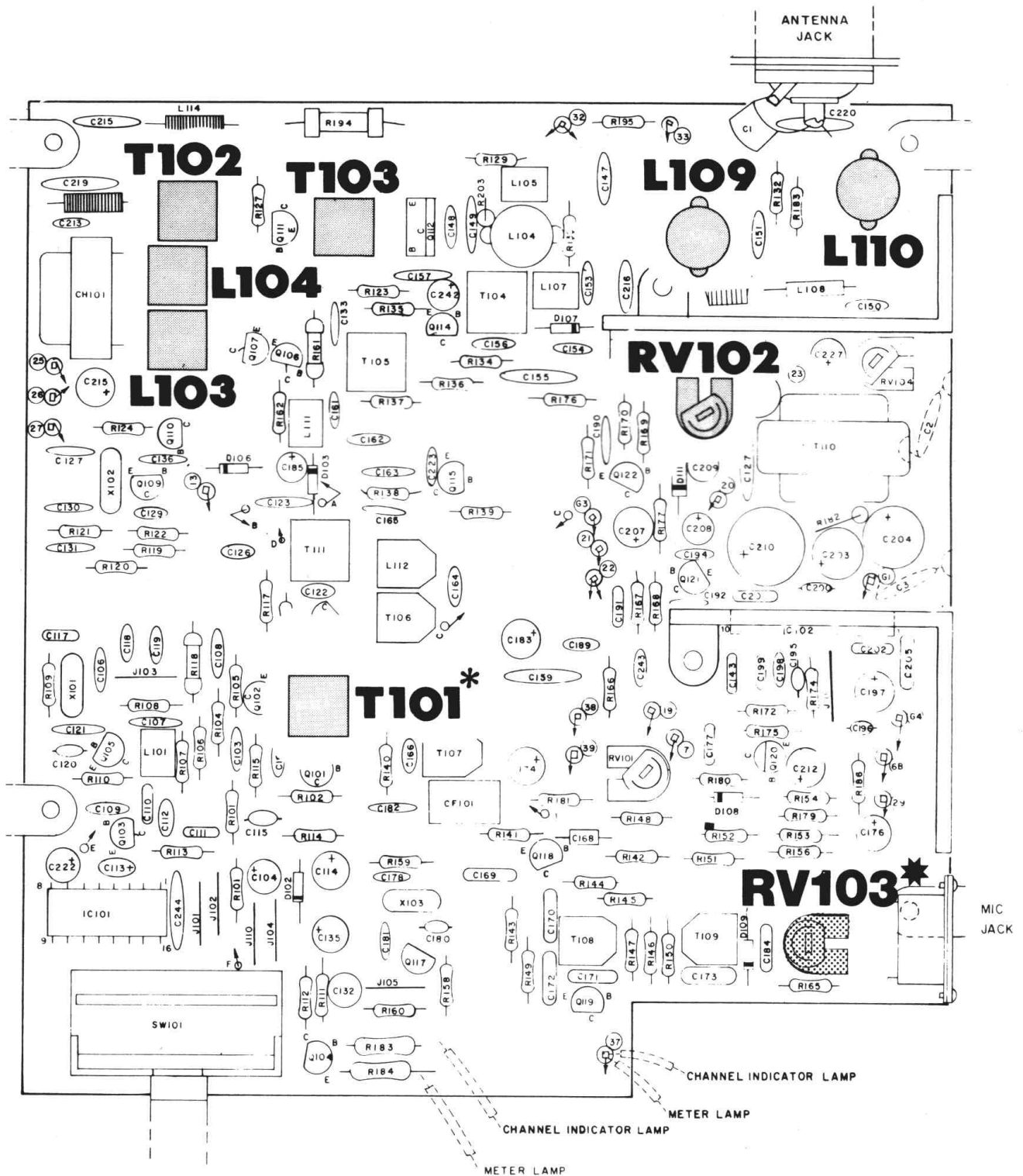

Figure 3-6. Components Adjusted for Power Supply Alignment



NOTES:

- *RV103 is not adjusted in Model 3087 for transmitter alignment.
- *T101 is adjusted for VCO alignment only.

Figure 3-7. Components Adjusted for Transmitter Alignment

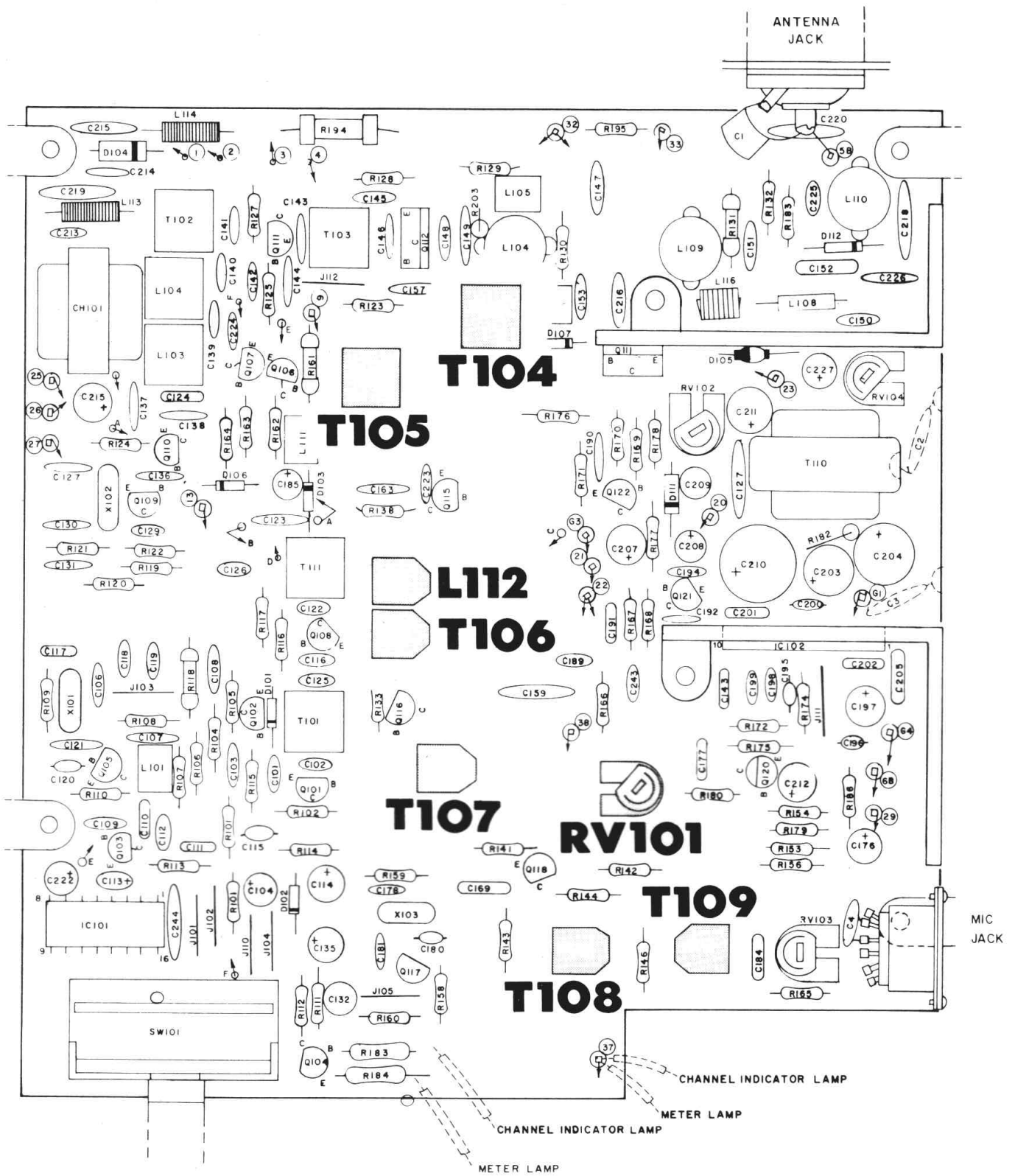

Figure 3-8. Components Adjusted for Receiver Alignment

CHAPTER 4 - CHARTS AND DRAWINGS

Voltage Charts

VOLTAGE MEASUREMENT CHART

Ref Desig.	Mode	E	B	C
Q101	RX	0	.70V	2.25V
	TX	0	.70V	2.25V
Q102	RX	0	.66V	2.77V
	TX	0	.66V	2.77V
Q103	RX	0	.65V	2.12V
	TX	0	.65V	2.12V
Q104	RX	0	.65V	2.17V
	TX	0	.65V	2.17V
Q105	RX	2.46V	3.09V	3.91V
	TX	2.46V	3.09V	3.91V
Q106	RX	8.66V	9.34V	12.54V
	TX	8.66V	9.34V	12.54V
Q107	RX	8.67V	8.13V	.39V
	TX	8.75V	8.05V	8.68V
Q108	RX	.78V	0	3.98V
	TX	.78V	0	3.98V
Q109	RX	0	.31V	.31V
	TX	2.7V	2.8V	4.45V
Q110	RX	0	0	.37V
	TX	1.9V	2.6V	8.8V
Q111	RX	1.76V	2.49V	13.66V
	TX	1.7	2.4	13.5V
Q112	RX	0	0	13.38V
	TX	0	0	11.0V
Q113	RX	0	0	13.4V
	TX	0	0	11.8V
Q114	RX	1.55V	2.20V	12.71V
	TX	.38	.38V	13.0V
Q115	RX	1.54V	2.25V	12.09V
	TX	8.1V	.47V	13.25V
Q116	RX	0	.61V	0
	TX	0	.61V	0
Q117	RX	2.07V	2.64V	3.54V
	TX	2.07V	2.64V	3.54V
Q118	RX	1.48V	2.17V	12.11V
	TX	.1V	.35V	13V
Q119	RX	.57V	1.26V	12.68V
	TX	.15V	.25V	13V
Q120	SQ	0	.03V	6.68V
	UNSQ	0	.66V	.07V
Q121	RX	0	0	0
	TX	0	0	0
Q122	RX	0	.6V	0
	TX	0	.6V	0

Power Supply

Ref. Des.	Mode	E	B	C
Q1	RX	0	-0.04	-0.04
Q2	RX	0	0	-0.03
Q3	RX	0	0	-0.03

IC 101 (P.L.L. 02A)

Pin. No.	Voltage	Channels Selected
1	4.7	N/A
2	1.8	N/A
3	2.8	N/A
4	4.6	N/A
5	1.5 - 2.5	All Channels
6	4.2	N/A
7	0	N/A
8	4.7	N/A
9	4.7	N/A
10	4.7	N/A
11	4.7	14, 15, 16, 17, 18, 19, 20, 21, 22, 23
12	4.7	8, 9, 10, 12, 13, 20, 21, 22, 23
13	4.7	4, 5, 6, 7, 11, 12, 13, 17, 18, 19, 23
14	4.7	3, 6, 7, 9, 10, 12, 13, 16, 19, 22
15	4.7	2, 5, 7, 8, 10, 13, 15, 16, 18, 21, 23
16	0	N/A

IC 102 (BA 521)

Pin No.	1	2	3	4	5	6	7	8	9	10
Squelched	12.69V	0V	0V	6.76V	6.58V	2.45V	.10V	13.61V	13.64V	13.71V
Unsquelched	6.82V	0V	1.28V	6.67V	6.67V	6.70V	.98V	8.06V	13.39V	13.7V



**Component Outline
Main P.C. Board**

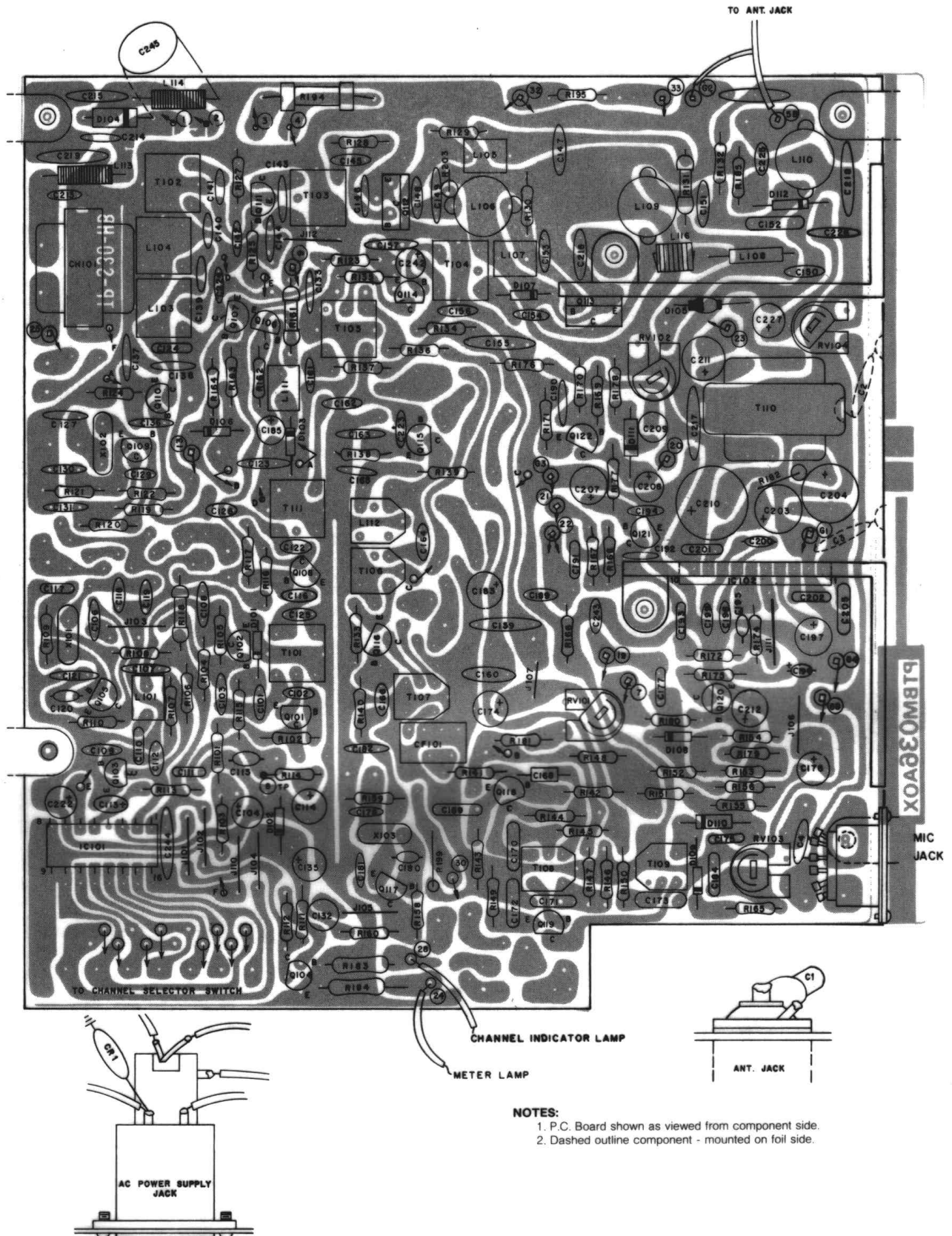
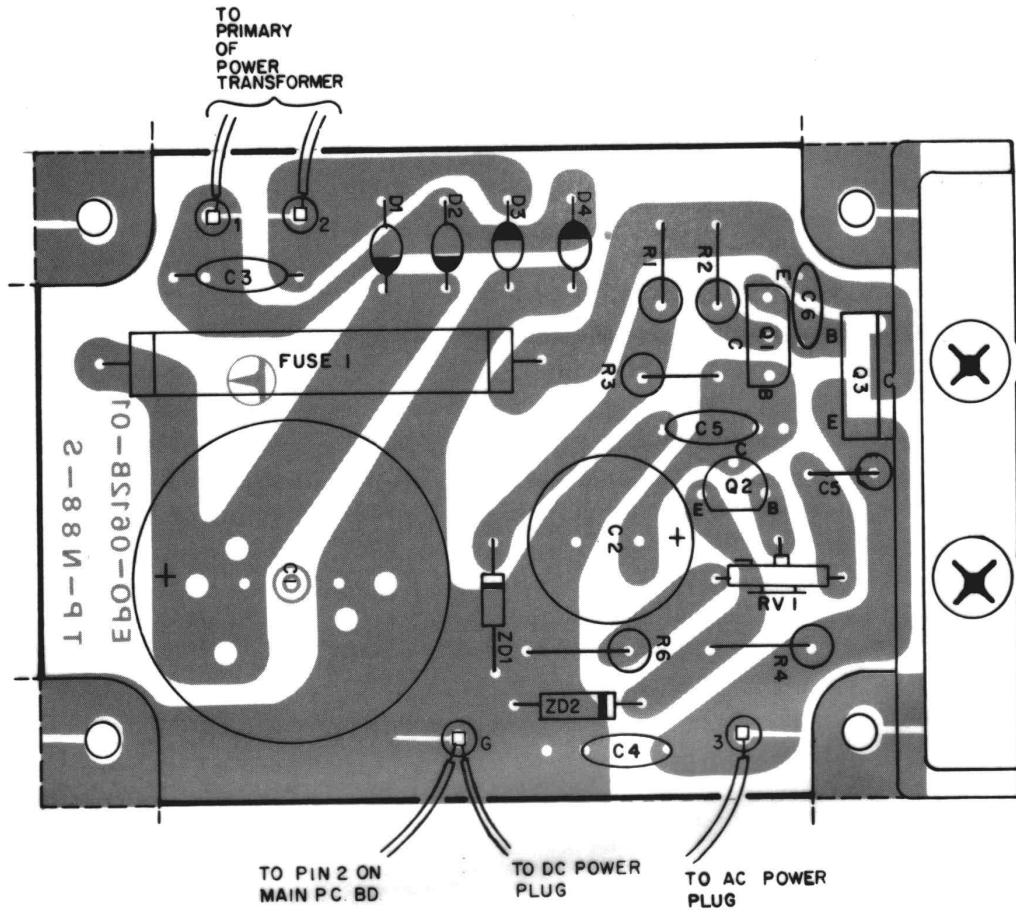

Figure 4-1. Component Outline Main P.C. Board, Model 3087

**Component Outline
Power Supply P.C. Board**



NOTE:
P.C. Board shown as viewed from component side.

Figure 4-2. Component Outline Power Supply P.C. Board, Model 3087

Parts List

Main P.C. Board

Reference Designator	Description	Part No.
	main, p.c. board, complete	APTBM36AT
	main, p.c. board, plated and drilled	PTBM36AOX
C101	18pF, 50V, ceramic disc	CC-CB180KCM
C102	22pF, 50V, ceramic disc	CC-CB220KOM
C103	1pF, 50V, ceramic disc	CC-CB010CCM
C104	10uF, 16V, electrolytic	CE-ED100ALN
C105	(not used)	
C106	10pF, 50V, ceramic disc	CC-CB100DOM
C107	.01uF, 50V, ceramic disc	CK-CB103PEM
C108	330pF, 50V, ceramic disc	CC-CB331KOM
C109	330pF, 50V, ceramic disc	CC-CB331KOM
C110	.001uF, 50V, mylar	CQ-MB102KCH
C111	.01uF, 50V, mylar	CQ-MB103KCH
C112	39pF, 50V, ceramic disc	CC-CB390KOM
C113	22uF, 50V, electrolytic	CE-EGR22ZMN
C114	10uF, 16V, electrolytic	CE-ED100KMN
C115	.1uF, 50V, electrolytic	CE-EGR10ZMN
C116	16pF, 50V, ceramic disc	CC-CB150KOM
C117	.01uF, 50V, mylar	CQ-MB103KCH
C118	56pF, 50V, ceramic disc	CC-CB569KPM
C119	12pF, 50V, ceramic disc	CB-CC1201CPM
C120	560pF, 50V, ceramic disc	CK-CB561KBM
C121	100pF, 50V, ceramic disc	CC-CB101KPM
C122	15pF, 50V, ceramic disc	CC-CB150KOM
C123	.01uF, 50V, ceramic disc	CC-CB103PEM
C124	100pF, 500V, mica	CM-SD101KCS
C125	33pF, 50V, ceramic disc	CC-CB330KOM
C126	12pF, 50V, ceramic disc	CC-CB120KPM
C127	56pF, 50V, ceramic disc	CC-CB560KPM
C128	(not used)	
C129	560pF, 50V, ceramic disc	CK-CB561KBM
C130	82pF, 50V, ceramic disc	CC-CB820KPM
C131	.01uF, 50V, ceramic disc	CK-CB103PEM
C132	560pF, 50V, mylar	CQ-MB561KCH
C133	.01uF, 50V, ceramic disc	CK-CB103PEM
C134	(not used)	
C135	10uF, 16V, electrolytic	CE-ED100ALN
C136	220pF, 50V, ceramic disc	CC-CB221KOM
C137	.01uF, 50V, ceramic disc	CK-CB103PEM
C138	.01uF, 50V, ceramic disc	CK-CB103PEM
C139	2pF, 50V, ceramic disc	CC-CB020COM
C140	2pF, 50V, ceramic disc	CC-CB020COM
C141	68pF, 50V, ceramic disc	CC-CB680KOM
C142	.01uF, 50V, ceramic disc	CK-CB103PEM
C143	100pF, 50V, ceramic disc	CC-CB101KPM
C144	.01uF, 50V, ceramic disc	CK-CB103PEM
C145	.01uF, 50V, ceramic disc	CK-CB103PEM
C146	470pF, 50V, ceramic disc	CK-CB471KBM
C147	.01uF, 50V, ceramic disc	CK-CB103PEM
C148	120pF, 50V, ceramic disc	CC-CB121KPM
C149	220pF, 50V, ceramic disc	CC-CB221KOM
C150	.01uF, 50V, ceramic disc	CK-CB103PEM
C151	100pF, 500V, mica	CM-SD101KCS
C152	270pF, 500V, mica	CM-SD271KCS
C153	82pF, 50V, ceramic disc	CC-CB820KOM
C154	27pF, 50V, ceramic disc	CC-CB270KOM
C155	.047uF, 50V, ceramic disc	CK-CB473ZFM
C156	.01uF, 50V, ceramic disc	CK-CB103PEM
C157	.01uF, 50V, ceramic disc	CK-CB103PEM
C158	(not used)	

Reference Designator	Description	Part No.
C159	.047uF, 50V, ceramic disc	CK-CB473ZFM
C160	.047uF, 50V, mylar	CQ-MB473KCH
C161	.01uF, 50V, ceramic disc	CK-CB103PEM
C162	33pF, 50V, ceramic disc	CC-CB330KPM
C163	.01uF, 50V, ceramic disc	CK-CB103PEM
C164	2pF, 50V, ceramic disc	CC-CB020COM
C165	.01uF, 50V, ceramic disc	CK-CB103PEM
C166	10pF, 50V, ceramic disc	CC-CB100DOM
C167	(not used)	
C168	2.2pF, 500V, ceramic disc	CG-2H2R2KNN
C169	.047uF, 50V, mylar	CQ-MB473KCH
C170	.047uF, 50V, mylar	CQ-MB473KCH
C171	.047uF, 50V, mylar	CQ-MB473KCH
C172	.047uF, 50V, mylar	CQ-MB473KCH
C173	.047uF, 50V, mylar	CQ-MB473KCH
C174	3.3uF, 25V, electrolytic	CE-EE3R3ALN
C175	.0047uF, 50V, mylar	CQ-MB472KCH
C176	1uF, 50V, electrolytic	CE-EGO10ALN
C177	2200pF, 50V, mylar	CQ-MB223KCH
C178	56pF, 50V, ceramic disc	CC-CB560KPM
C179	(not used)	
C180	560pF, 50V, ceramic disc	CK-CB561KBM
C181	100pF, 50V, ceramic disc	CC-CB101KOM
C182	68pF, 50V, ceramic disc	CC-CB680KPM
C183	10uF, 16V, electrolytic	CE-ED100ALN
C184	22uF, 50V, ceramic disc	CK-CC222KBM
C185	47uF, 16V, electrolytic	CE-ER470ALN
C186 through		
C188	(not used)	
C189	0022uF, 50V, ceramic disc	CK-CC222KBM
C190	.01uF, 50V, ceramic disc	CK-CB103PEM
C191	.022uF, 50V, mylar	CQ-MB223KCH
C192	150pF, 50V, ceramic disc	CC-CB151KOM
C193	.01uF, 50V, mylar	CQ-MB103KCH
C194	.01uF, 50V, ceramic disc	CK-CB103PEM
C195	390pF, 50V, ceramic disc	CK-CB391KBM
C196	5.6uF, 25V, tantalum	CS-SE5R6MDN
C197	33uF, 6.3V, electrolytic	CE-EB330ALN
C198	68pF, 50V, ceramic disc	CC-CB680KOM
C199	68pF, 50V, ceramic disc	CC-CB680KOM
C200	390pF, 50V, ceramic disc	CK-CB391KBM
C201	.068uF, 50V, mylar	CQ-MB683KCH
C202	.022uF, 50V, mylar	CQ-MB223KCH
C203	47uF, 16V, electrolytic	CE-ED470ALN
C204	220uF, 16V, electrolytic	CE-AD221ZLS
C205	.068uF, 50V, mylar	CQ-MB683KCH
C206	(not used)	
C207	33uF, 6.3V, electrolytic	CE-EB330ALN
C208	10uF, 16V, electrolytic	CE-ED100ALN
C209	1uF, 50V, electrolytic	CE-EGO10ALN
C210	1000uF, 16V, electrolytic	CE-ED102ZUN
C211	47uF, 25V, electrolytic	CE-AE470ZLS
C212	33uF, 6.3V, electrolytic	CE-EB330ALN
C213	.01uF, 50V, ceramic disc	CK-CB103PEM
C214	.01uF, 50V, ceramic disc	CK-CB103PEM
C215	.01uF, 50V, ceramic disc	CK-CB103PEM
C216	.01uF, 50V, ceramic disc	CK-CB103PEM
C217	.047uF, 50V, ceramic disc	CK-CB473ZFM
C218	.047uF, 50V, ceramic disc	CK-CB473ZFM
C219	.047uF, 50V, ceramic disc	CK-CB473ZFM
C220	.047uF, 50V, ceramic disc	CK-CB473ZFM
C221	(not used)	
C222	4.7uF, 25V, electrolytic	CE-EE4R7ZMN
C223	39pF, 50V, ceramic disc	CC-CB390KOM
C224	.01uF, 50V, ceramic disc	CK-CB103PEM
C225	4pF, 500V, ceramic disc	CC-EE040COM
C226	1uF, 50V, electrolytic	CE-EGO10ALN

Designator Reference	Description	Part No.
C227	1uF, 50V, electrolytic	CE-EG010ALN
C228 through C241	(not used)	
C242	1uF, 50V, electrolytic	CE-EG010ALN
C243	100pF, 50V, ceramic disc	CC-CB101KOM
C244	.047uF, 50V, ceramic disc	CK-CB473ZFM
C245	2.2uF, 50V, mica	CM-SO221KCS
CF101	ceramic filter	FB-R455A98M
CH101	choke coil	LJ-119H001Y
D101	1TT410, silicon	QD-CTT410XQ
D102	MZ205, silicon, zener	QD-ZMZ205XE
D103	RD9.1E, silicon, zener	QD-ZRD9EXAA
D104	1S1885, silicon	QD-SS1885XT
D105	V06C, silicon	QD-SV06CXXB
D106	1S1555, silicon	QD-SS1555XT
D107	1S1555, silicon	QD-SS1555XT
D108	1S1555, silicon	QD-SS1555XT
D109	(not used)	
D110	1N60, germanium	QD-G1N60XXT
D111	1N60, germanium	QD-G1N60XXT
D112	1N60, germanium	QD-G1N60XXT
IC101	PLL02A	QQ-OPLL02AO
IC102	(TOYO) BA521	QQ-MBA521AX
L101	rf coil	LF-220KD01N
L102	(not used)	
L103	rf coil	TR-10CD004S
L104	rf coil	TR-10CD005S
L105	rf coil	LF-2R2KD01N
L106	rf coil	TR-A5CZ001M
L107	rf coil	LF-680KD01N
L108	rf coil	LF-ADX3825M
L109	rf coil	TR-A5CZ002M
L110	rf coil	TR-A5CZ003M
L111	rf coil	LF-680KD01N
L112	rf coil	TR-07MB008N
L113	rf coil	LD-ADB4024B
L114	rf coil	LD-ADB4024B
L115	(not used)	
L116	rf coil	LA-1KE1011A
Q101	(MITSUBISHI) 2SC710(D)	QT-C0710XBE
Q102	(MITSUBISHI) 2SC710(D)	QT-C0710XBE
Q103	(NEC) 2SC829(B)	QT-CO829SAN
Q104	(MITSUBISHI) 2SC710(D)	QT-C0710XBE
Q105	(MITSUBISHI) 2SC710(D)	QT-C0710XBE
Q106	(MITSUBISHI) 2SC1318(Q)	QT-C1318XAN
Q107	(MITSUBISHI) 2SA719(Q)	QT-A0719XAN
Q108	(NEC) 2SC1359(B)	QT-C1359XAN
Q109	(MITSUBISHI) 2SC710(D)	QT-C0710XBE
Q110	(MITSUBISHI) 2SC710(D)	QT-C0710XBE
Q111	2SC1687	QT-C1687XAN
Q112	(SONY) 2SC1760-3	QT-C1760XAS
Q113	(NEC) 2SC1306	QT-C1306XZA
Q114	2SC1047(B)	QT-C1047XAN
Q115	(NEC) 2SC1359(B)	QT-C1359XAN
Q116	(NEC) 2SC829(C)	QT-CO829XBN
Q117	(MITSUBISHI) 2SC710(D)	QT-C0710XBE
Q118	(NEC) 2SC829(C)	QT-CO829XBN
Q119	(NEC) 2SC829(C)	QT-CO829XBN
Q120	2SC372(Y)	QT-CO372XAT

Reference Designator	Description	Part No.
Q121	2SC828P.Q	QT-C0828XDN
Q122	2SC828P	QT-C0828XAN
R101	100, 5%, 1/4w, carbon film	RD-25RJ101D
R102	100k, 5%, 1/4w, carbon film	RD-25RJ104D
R103	1.5k, 5%, 1/4w, carbon film	RD-25RJ152D
R104	1.5k, 5%, 1/4w, carbon film	RD-25RJ152D
R105	220, 5%, 1/4w, carbon film	RD-25RJ221D
R106	1.5k, 5%, 1/4w, carbon film	RD-25RJ152D
R107	100k, 5%, 1/4w, carbon film	RD-25RJ104D
R108	1.5k, 5%, 1/4w, carbon film	RD-25RJ152D
R109	100k, 5%, 1/4w, carbon film	RD-25RJ104D
R110	2.2k, 5%, 1/4w, carbon film	RD-25RJ222D
R111	1k, 5%, 1/4w, carbon film	RD-25RJ102D
R112	100k, 5%, 1/4w, carbon film	RD-25RJ104D
R113	3.3k, 5%, 1/4w, carbon film	RD-25RJ332D
R114	470, 5%, 1/4w, carbon film	RD-25RJ471D
R115	22k, 5%, 1/4w, carbon film	RD-25RJ223D
R116	470, 5%, 1/4w, carbon film	RD-25RJ471D
R117	33k, 5%, 1/4w, carbon film	RD-25RJ333D
R118	100, 5%, 1/2w, metal oxide	RG-HAPJ101B
R119	1.5k, 5%, 1/4w, carbon film	RD-25RJ152D
R120	100k, 5%, 1/4w, carbon film	RD-25RJ104D
R121	1k, 5%, 1/4w, carbon film	RD-25RJ102D
R122	1k, 5%, 1/4w, carbon film	RD-25RJ102D
R123	82k, 5%, 1/4w, carbon film	RD-25RJ823D
R124	270, 5%, 1/4w, carbon film	RD-25RJ271D
R125	10k, 5%, 1/4w, carbon film	RD-25RJ103D
R126	(not used)	
R127	68, 5%, 1/4w, carbon film	RD-25RJ680D
R128	100, 5%, 1/4w, carbon film	RD-25RJ101D
R129	220, 5%, 1/4w, carbon film	RD-25RJ221D
R130	47, 5%, 1/4w, carbon film	RD-25RJ470D
R131	10, 5%, 1/2w, metal oxide	RX-HAPJ100B
R132	47k, 5%, 1/4w, carbon film	RD-25RJ473D
R133	1k, 5%, 1/4w, carbon film	RD-25RJ102D
R134	680, 5%, 1/4w, carbon film	RD-25RJ681D
R135	1.5k, 5%, 1/4w, carbon film	RD-25RJ152D
R136	100, 5%, 1/4w, carbon film	RD-25RJ101D
R137	1.8k, 5%, 1/4w, carbon film	RD-25RJ182D
R138	1k, 5%, 1/4w, carbon film	RD-25RJ102D
R139	470, 5%, 1/4w, carbon film	RD-25RJ471D
R140	100k, 5%, 1/4w, carbon film	RD-25RJ104D
R141	1k, 5%, 1/4w, carbon film	RD-25RJ102D
R142	4.7k, 5%, 1/4w, carbon film	RD-25RJ472D
R143	470, 5%, 1/4w, carbon film	RD-25RJ471D
R144	4.7k, 5%, 1/4w, carbon film	RD-25RJ473D
R145	220, 5%, 1/4w, carbon film	RD-25RJ221D
R146	330, 5%, 1/4w, carbon film	RD-25RJ331D
R147	1.5k, 5%, 1/4w, carbon film	RD-25RJ152D
R148	27k, 5%, 1/4w, carbon film	RD-25RJ273D
R149	220, 5%, 1/4w, carbon film	RD-25RJ221D
R150	47, 5%, 1/4w, carbon film	RQ-25RJ470D
R151	22k, 5%, 1/4w, carbon film	RD-25RJ223D
R152	270k, 5%, 1/4w, carbon film	RD-25RJ474D
R153	47k, 5%, 1/4w, carbon film	RD-25RJ473D
R154	68k, 5%, 1/4w, carbon film	RD-25RJ683D
R155	33k, 5%, 1/4w, carbon film	RD-25RJ333D
R156	47k, 5%, 1/4w, carbon film	RD-25RJ473D
R157	(not used)	
R158	100k, 5%, 1/4w, carbon film	RD-25RJ104D
R159	1.5k, 5%, 1/4w, carbon film	RD-25RJ152D
R160	1.5k, 5%, 1/4w, carbon film	RD-25RJ152D
R161	22, 5%, 1/2w, metal oxide	RG-HAPJ220B
R162	1k, 5%, 1/4w, carbon film	RD-25RJ102D
R163	390, 5%, 1/4w, carbon film	RD-25RJ391D

Reference Designator	Description	Part No.
R164	10k, 5%, 1/4w, carbon film	RD-25RJ103D
R165	820, 5%, 1/4w, carbon film	RD-25RJ821D
R166	3.3k, 5%, 1/4w, carbon film	RD-25RJ332D
R167	27k, 5%, 1/4w, carbon film	RD-25RJ273D
R168	3.3k, 5%, 1/4w, carbon film	RD-25RJ332D
R169	220k, 5%, 1/4w, carbon film	RD-25RJ224D
R170	22k, 5%, 1/4w, carbon film	RD-25RJ223D
R171	150, 5%, 1/4w, carbon film	RD-25RJ151D
R172	2.2k, 5%, 1/4w, carbon film	RD-25RJ222D
R173	(not used)	
R174	10, 5%, 1/4w, carbon film	RD-25RJ100D
R175	10k, 5%, 1/4w, carbon film	RD-25RJ103D
R176	82, 5%, 1/4w, carbon film	RD-25RJ820D
R177	270, 5%, 1/4w, carbon film	RD-25RJ271D
R178	680, 5%, 1/4w, carbon film	RD-25RJ681D
R179	22k, 5%, 1/4w, carbon film	RD-25RJ223D
R180	1.8k, 5%, 1/4w, carbon film	RD-25RJ182D
R181	18k, 5%, 1/4w, carbon film	RD-25RJ183D
R182	100, 5%, 1/4w, carbon film	RD-14VJ101D
R183	270, 5%, 1/4w, metal oxide	RG-HAPJ271B
R184	270, 10%, 1/2w, solid carbon	RG-HAPJ271B
R185	100, 5%, 1/4w, carbon film	RD-25RJ101D
R186 through		
R193	(not used)	
R194	15, 5%, 2w, metal oxide	RX-2ANJ150N
R195	1.5k, 5%, 1/4w, carbon film	RD-25RJ152D
R196 through		
R198	(not used)	
R199	270, 10%, 1/2w, solid carbon	RG-HAPJ271B
R200 through		
R202	(not used)	
R203	560, 5%, 1/4w, carbon film	RD-25RJ561D
R204	(not used)	
RV101	10k, potentiometer	RP-GNB10301
RV102	2k, potentiometer	RP-GNB20201
SW101	switch, rotary wafer	SR-0724102W
T101	rf transformer	TR-10DA002T
T102	rf transformer	TR-10CB001S
T103	rf transformer	TR-10CP005S
T104	rf transformer	TR-10MP003T
T105	rf transformer	TR-10CA005S
T106	rf transformer	TR-07MB008N
T107	i-f transformer	TR-07LA004N
T108	i-f transformer	TR-07LA005N
T109	i-f transformer	TR-07LA023N
T110	af transformer	TB-G25B001W
T111	i-f transformer	TR-10MB003T
X101	11 8066 MHz, crystal	XA-SIB4001N
X102	10 695 MHz, crystal	XA-S1B3002N
X103	10.240 MHz, crystal	XA-AIB3001N

Power Supply P.C. Board

Reference Designator	Description	Part No.
	power supply p.c. board, complete	AP-TPW005AA
	power supply p.c. board, plated and drilled	PT-TW005COX
C1	2200uF, 25V, electrolytic	CE-T1E22201
C2	100uF, 25V, electrolytic	CE-AE101ALN
C3	.022uF, 50V, ceramic disc	CK-RB223PZM
C4	.01uF, 50V, ceramic disc	CK-RB103PZM
C5	.047uF, 50V, ceramic disc	CK-RB473PMM
C6	.022uF, 50V, ceramic disc	CK-RB223PMM
D1	VO6C, silicon	QD-SV06CXXB
D2	VO6C, silicon	QD-SV06VXXB
D3	VO6C, silicon	QD-SV06CXXB
D4	VO6C, silicon	QD-SV06CXXB
F1	fuse 250V, 3/4A	ZF-BQ75101U
Q1	(NEC) 2SC900F	QT-C0900XBA
Q2	(NEC) 2SC900F	QT-C0900XBE
R1	220, 5%, 1/2w, solid carbon	RC-12GK221N
R2	47, 5%, 1/2w, solid carbon	RC-12GK470N
R3	100, 5%, 1/2w, solid carbon	RC-12GK101N
R4	820, 5%, 1/2w, solid carbon	RC-12GK821N
R5	1.2k, 5%, 1/2w, solid carbon	RC-12GK122N
R6	820, 5%, 1/2w, solid carbon	RC-12GK820N
RV1	500, potentiometer	RP-ANB50101
ZD1	BZ-162, silicon, zener	QD-ZBZ162XJ
ZD2	RD5.6E(C), silicon, zener	QD-ZRD56EAA

Chassis Mounted Components

Reference Designator	Description	Part No.
C1	220pF, 500V, mica	CM-SD221KCS
C2	.01uF, 50V, ceramic disc	CK-DB103PEM
C3	.01uF, 50V, ceramic disc	CK-DB103PEM
C4	.01uF, 50V, ceramic disc	CK-DB103PEM
CR1	CR module	CR-E471A01M
F1	fuse, 250V, 2.5A	ZF-AQ25201U
J1	jack, antenna	YJ-C02S008Z
J2	jack, 5 pin, DIN, microphone	YJ-D05S001Z
J3	jack, phone	YJ-S03S010Z
J4	jack, phone	YJ-S04S002Z
J5	jack, DC power	YJ-B02S001U
J6	jack, AC power	YJ-A02S001U
M	meter	ZM-J2050N02
PL1	lamp, pilot	ZP-A064102U
PL2	lamp, pilot	ZP-A064102U
PL3	lamp, pilot	ZP-A064102U

Reference Designator	Description	Part No.
Q3	(SANYO) 2SD313	QT-D0313XAC
S1	on/off power switch (part of volume control)	RV-AD503A04
SP	speaker, 8 ohm.	ZQ-A0770802
VR1	50k. potentiometer (volume control)	RV-AD503A04
VR2	10k. potentiometer (squelch control)	RV-NA103B03
	transformer, power	TP-H68G001K

Mechanical Parts

Part No.	Description	Qty.
AM-3077#01	cabinet assembly, upper	1
AM-3077#02	cabinet assembly, lower	1
MB-871SZ009	chassis, main frame	1
MZ-111SZ002	bracket, speaker holding	1
AV-KNOB#044	knob, channel select	1
AV-KNOB#045	knob, volume and squelch	2
AV-KNOB#046	plate, channel	1
MB-763SZ003	panel, rear	1
MU-443SZ002	bracket, phone jack mounting	1
MU-443SZ001	bracket, mic jack mounting	1
MC-576XZ001	bracket, rotary switch mounting	1
AC-AC008ULA	cord, AC power	1
AC-DC034ULA	cord, DC power	1

Accessory Parts

Part No.	Description	Qty.
ZG-AAZ70101	microphone	1



**Schematic Diagram
Model 3087**

HY-GAIN DE PUERTO RICO, INC.

P.O. Box 68 State Hwy 31, Km. 4.0
Naguabo, Puerto Rico 00718